

# Case Study

S&S Machine



S&S Machine Reduces Costs by Implementing Quality Processes Automation with **InspectionXpert**.



*"After a day of training, it only took a week to get our internal procedures and templates in place. We then started rolling."*

## The Challenge

*"FAIs were taking too long and the error rate was high. Simple FAI's were taking several hours, and more complex ones would take almost a full day."*



## The Solution

*"After trying InspectionXpert, I stopped looking. From there everything went very quickly, with a day of training for my quality team, and then a week getting our internal procedures and templates in place, we started rolling."*

Started in 1978, **S&S Machine** in Irving, Texas offers a full complement of CNC and manual equipment for sheet metal, milling, water jet cutting, industrial silk screening, and assembly requirements. Many of their major customers like Boeing and other aerospace suppliers have a high standard for quality documentation, such as AS9102B compliant FAIs. Recently we spoke to their quality manager about his decision to use InspectionXpert OnDemand and the results he achieved.

When Jimmy Dereta, joined S&S Machining as Quality Manager, he confronted significant challenges. FAIs were taking too long and the error rate was high. Simple FAI's were taking several hours, and more complex ones would take almost a full day. From years of manual FAIs, many FAIs were discovered with errors and mistakes back to 2005. As a result, several major customers were rejecting FAIs and placed jobs on hold until the mistakes were corrected. In addition to strained customer relations, the Quality Department was not running as well as it could with everyone consumed with, paperwork and dealing with customer reject issues.

Jimmy had seen InspectionXpert OnDemand software, and had heard about the benefits from other companies. While Jimmy considered other solutions, the ease of use and powerful features offered by InspectionXpert OnDemand was a major factor, in its selection.

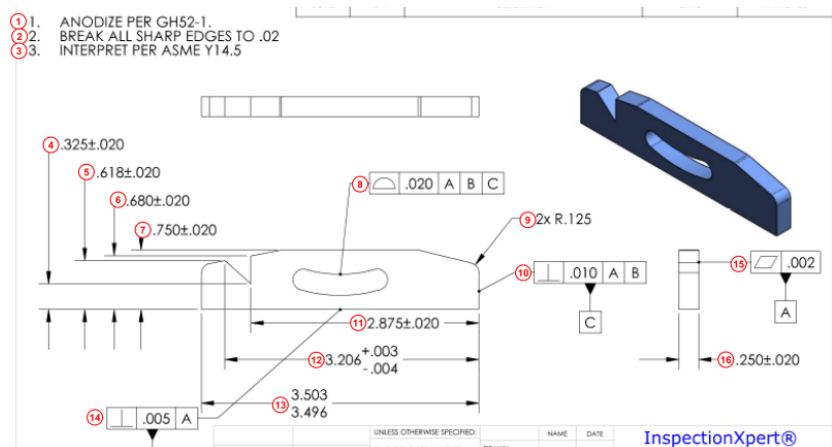

*"The time savings and improvements in accuracy made the business case simple!"*

## Results

*"A Quality Manager from a major customer complemented us on our improvements in FAI accuracy. I know one does not often earn complements like that so I was really proud of our team and our progress, thanks to InspectionXpert."*



## The ROI

*"I recommend every company that creates quality inspection documents to try InspectionXpert OnDemand; the improvements are tremendous and the cost savings and improved customer relationships are frankly invaluable."*

**The business case for InspectionXpert OnDemand is compelling.**

Almost immediately, the time it took to create accurate and complete quality inspection documents was dramatically reduced, by as much as 75%. With most FAIs created with InspectionXpert OnDemand errors and omissions were almost totally eliminated resulting in FAIs accepted on first submission. S&S customers liked being able to review the electronic files prior to an onsite inspection, and relationships improved.

**Prior to automating inspection planning with InspectionXpert OnDemand, S&S produced on average about:**

- \* 5 FAIs Per Day, or about 1250 FAIs per year
- \* 5 hours per FAI (includes simple to complex FAIs)
- \* 6250 hours per year (Hours do not include the time for error correction, rework, etc.)

**Labor rates/Manual FAI labor costs:**

- \* \$100/hour
- \* Total labor cost \$625,000 (\$100 x 6250 hours per year)

**\$468,750 Savings with InspectionXpert OnDemand:**

- \* Reduced Time per required FAI by 75% (5 hours to 1.25 per FAI)
- \* Reduced Labor cost \$468,750/Year ( Labor cost of manual FAIs \$625,000 <less> Reduced labor cost of \$156,250/Year (1250 FAIs x 1.25/Hours = 1562.5/Hours/Year x \$100/hour = \$156,250)

### Financial Benefit of InspectionXpert OnDemand at S & S Machine

	Using Old Methods	With InspectionXpert	Cost Savings
First-Article Inspection Planning	\$625,000	\$156,250	\$ 468,750



*“80% time savings and our largest customer is impressed!”*

## Update

---

*“Shops are moving towards in process inspection; having the ability to use InspectionXpert OnDemand in production where quality can verify and complete forms 1 and 2, has made the process much simpler.”*

---

**800.379.0322**  
**[www.inspectionxpert.com](http://www.inspectionxpert.com)**  
**[sales@inspectionxpert.com](mailto:sales@inspectionxpert.com)**

We recently had an opportunity to discuss S&S Machine’s implementation of InspectionXpert OnDemand with new quality manager John Sanders. John took the opportunity to affirm S&S Machine’s implementation of InspectionXpert OnDemand.

Tell us how you’ve been using our software, are there any key features or benefits that jump out?

**“Working with Boeing legacy drawings is tricky with having to manually input any data not recognized. Our end users found automation key to time savings and process improvement.”**

How have your customer’s responded to the automation of your quality process with InspectionXpert OnDemand?

**“Boeing is 85% of our customer base, they are impressed with InspectionXpert OnDemand and thrilled with implementation.”**

Are you still seeing a ROI in terms of labor savings?

**“We’ve seen an 80% time savings.”**

How has InspectionXpert OnDemand improved your quality process?

**“Customers want to see actual upper and lower limits for reporting. InspectionXpert OnDemand calculates this automatically.”**

What advice would you give to shops like yours who may be considering automating their quality inspection planning process?

**“Shops are moving towards in process inspection; having the ability to use InspectionXpert OnDemand in production where quality can verify and complete forms 1 and 2, has made the process much simpler.”**

